

## FIELD EVENTS DIAGRAMS

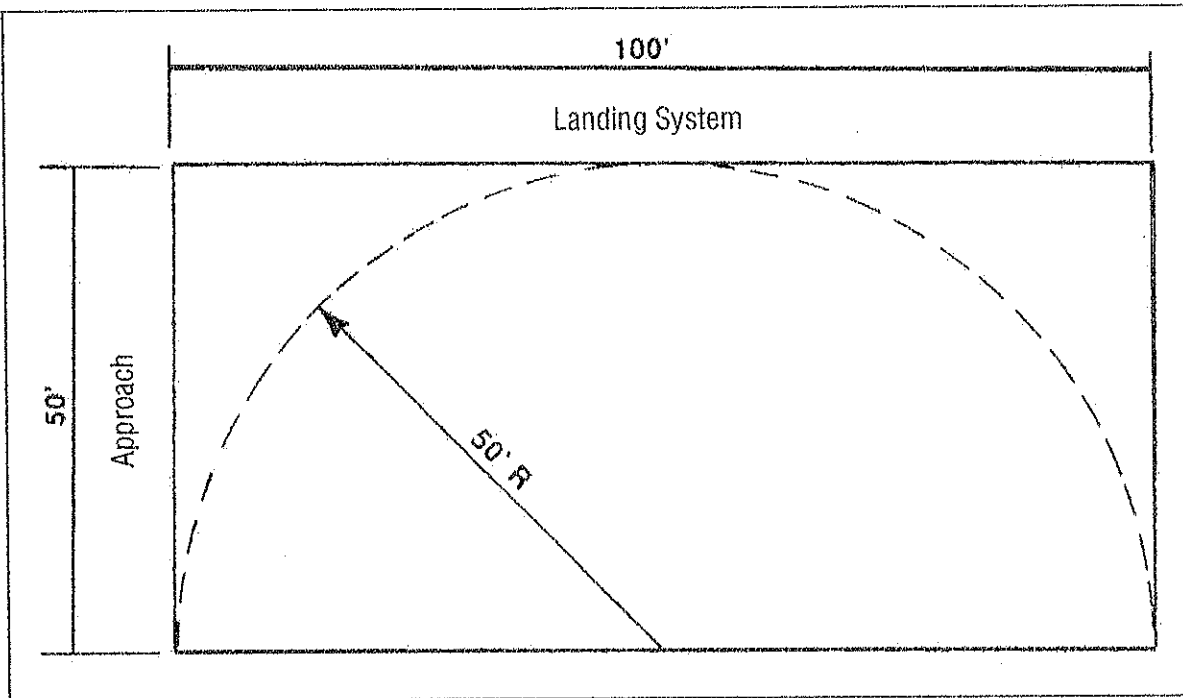

**HIGH JUMP** — The declination in the high jump approach shall not exceed 1:100 (1 percent).

The approach shall consist of a semicircle or rectangle of unvarying surface. The center of the semicircle or rectangle is to be the midpoint between the standards. The depth of the approach should be a minimum of 50 feet.

The landing pad shall not be less than 16 feet (4.80 meters) wide by 8 feet (2.40 meters) deep. The material in the pad shall be high enough and of a composition that will provide a safe landing. The rules committee strongly recommends the use of 24 inches (60 centimeters) of foam rubber or shock-absorbing synthetic soft material or an encased commercially compressed foam rubber mattress at least 18 inches (45 centimeters) thick.

When the landing pad is made up of two or more sections, they shall be attached and include a common cover or pad extending over all sections.

Hard and unyielding surfaces, such as concrete, wood or asphalt, that extend out from beneath the sides and back of the high-jump landing pad shall be padded with a minimum of 2-inch dense foam or other suitable material.

**NOTE:** It is recommended that any excess material such as asphalt or concrete that extends out from beneath the side or back of the landing pad be removed.

The upright standards which support the crossbar shall be at least 12 feet apart. The platforms which support the crossbar shall be rectangular planes  $1\frac{1}{2}$  inches by  $2\frac{3}{8}$  inches. The long dimensions shall point toward the opposite upright so that it will be parallel to the crossbar. There may be an extension of the standard above the crossbar. The base of the standards shall not be moved during the competition, and its position should be marked with tape prior to the start of competition.

The nonmetal crossbar shall not be less than 12 feet (3.66 meters) or more than 14 feet, 10 inches (4.52 meters) in length, of uniform thickness and shall have a weight of not more than 5 pounds. It shall be circular with a diameter of not more than  $1\frac{3}{16}$  inches and with the ends flattened to a surface  $1\frac{3}{16}$  inches by 6 inches to  $7\frac{3}{4}$  inches (150-200 millimeters).

**LONG JUMP AND TRIPLE JUMP** — The declination in the approach shall be limited to 2:100 (2 percent) laterally and 1:1,000 (0.1 percent) downward in the jumping direction.

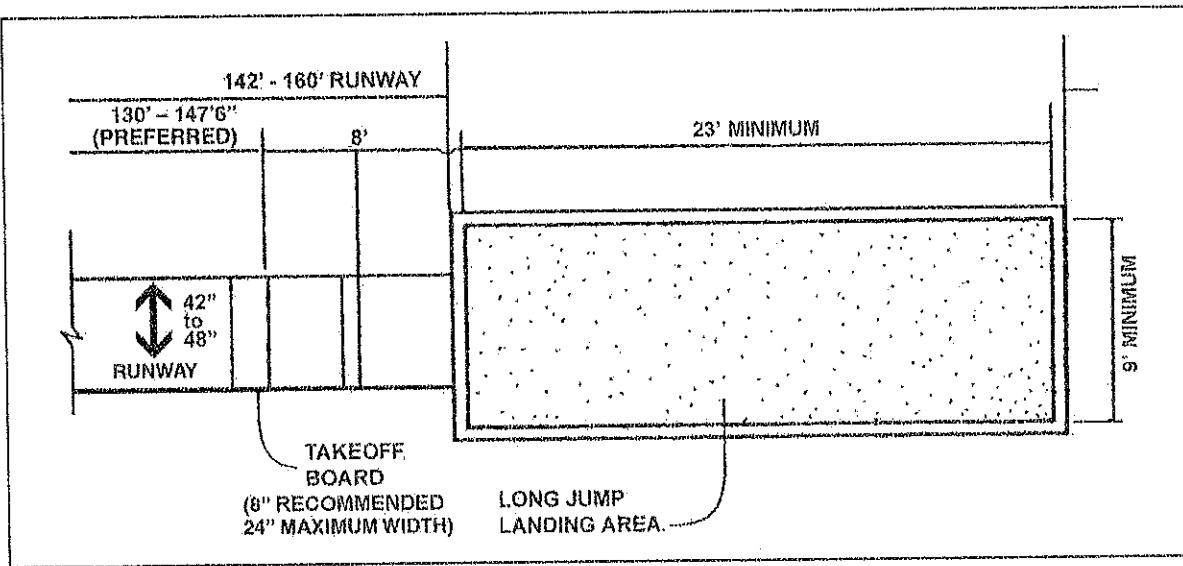

The runway should have a minimum length of 130 feet, and where conditions permit it should be 147 feet, 6 inches measured from the long-jump foul line. The runway should be 42 inches to 48 inches wide.

Equipment shall meet the following standards. The takeoff area shall be marked by a rectangular shaped takeoff board, manufactured from wood or synthetic material which provides a firm base, the width of which shall be between 8 inches (recommended) and 24 inches (maximum) and 42 inches to 48 inches long. The takeoff board shall be set firmly in the ground level with the runway and the surface of the landing pit. If the takeoff board is 8 inches wide, an additional 8 inches of firm, resilient material may be placed so that it abuts against the edge of the takeoff board farthest from the foul line.

On hard surfaced runways, a painted scratch line of a contrasting color and with the same size specifications may be used in lieu of a takeoff board.

The landing pit shall be filled with sand or other soft material to a depth at least 12 inches (30 centimeters). The surface shall have the same elevation as that of the take-off board. The landing pit shall have a minimum width of 9 feet (2.75 meters) and should meet a minimum length of 23 feet (7 meters). Pits constructed after 2019 shall be at least 23 feet (7 meters) in length. In the long jump and triple jump, the foul line shall be located by measuring from the nearer edge of the landing pit to the front of the foul line.

**NOTE:** Distances from the foul line or takeoff board may be adjusted to accommodate different levels of competition. Competitors may change which foul line or takeoff board they are using during competition, but only with the prior notification and confirmation of the event judge.

Suggested distances are:		
	Boys	Girls
Long Jump	12 feet (3.7 meters)	8 feet (2.5 meters)
Triple Jump	32 feet (9.8 meters)	24 feet (7.3 meters)

**POLE VAULT** — The declination in the approach shall be limited to 2:100 (2 percent) laterally and 1:1,000 (0.1 percent) downward in the running direction in the jumping direction.

**LANDING SYSTEM** — The standards or uprights shall be set to position the crossbar from a point 18 inches (45.7 centimeters) beyond the vertical plane of the top of the stopboard, zero (0) point, up to a maximum distance of 31.5 inches (80 centimeters) in the direction of the landing surface.

**RUNWAY** — A mark or marker shall not be placed on the runway, but it is permissible to place markers at the side of the runway. Meet management may provide check marks, not more than 3 inches

Diagram A

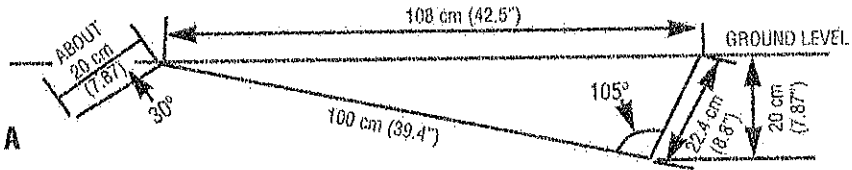

Diagram B

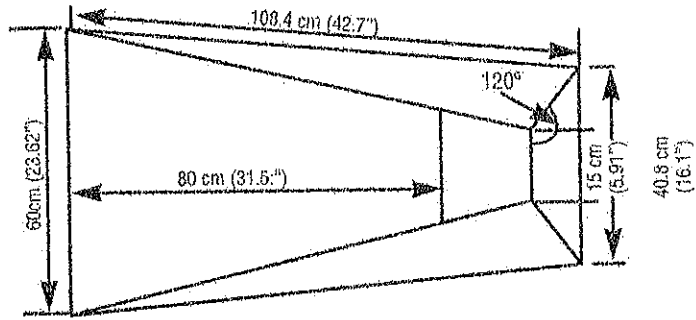

Diagram C

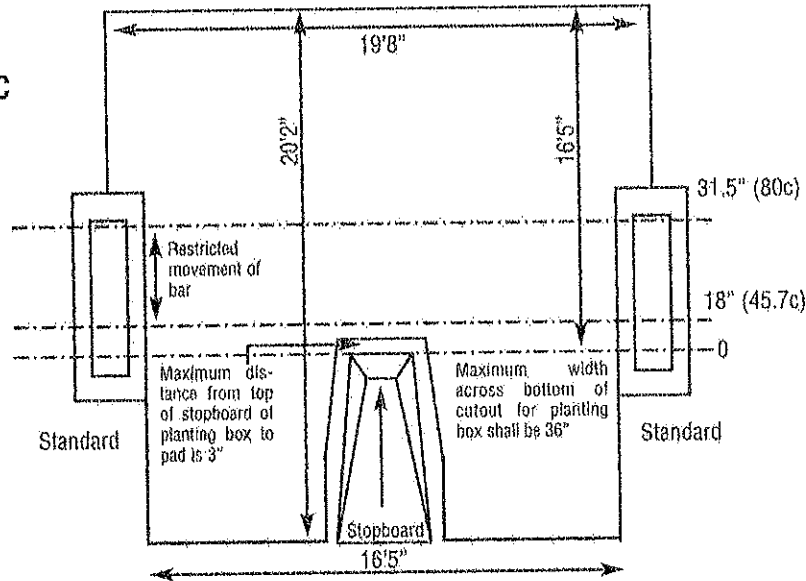
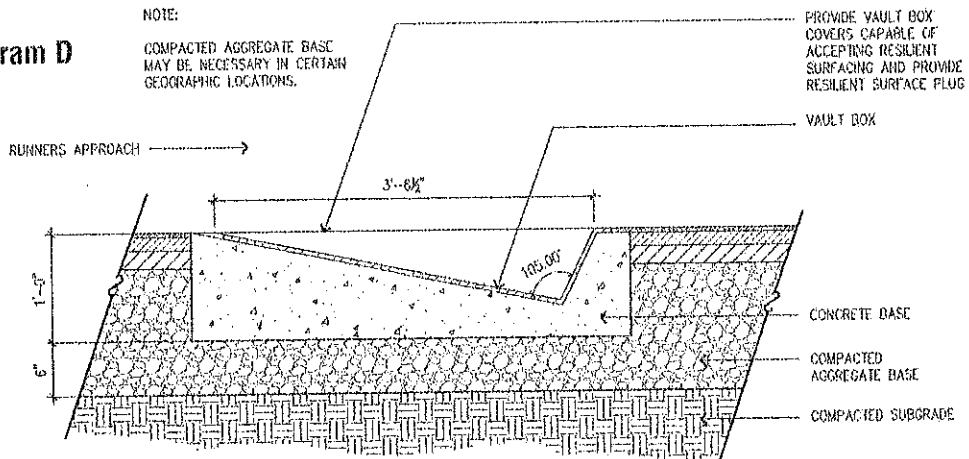

Diagram D



long, on the runway. Starting at the back of the planting box, mark intervals in the following manner: 6', 7', 8', 9', 10', 11', 12', 13', 20', 30', 40', 50', 60', 70', 80', 90', 100', 110', 120'. The recommended length of the runway is a minimum of 130 feet (40 meters). Where conditions permit, it should be 147 feet, 6 inches (45 meters). The runway should be at least up to 42 inches (1.07 meters) to 48 inches (1.22 meters) of usable runway wide whenever possible.

The overall size of the pole vault landing system shall be a minimum of 19 feet, 8 inches (6 meters) wide by 20 feet, 2 inches deep. The landing surface measured beyond the back of the standard bases, shall be a minimum of 19 feet, 8 inches (6 meters) wide. The dimension of the landing surface in back of the vaulting box to the back of the landing system shall be 16 feet, 5 inches (5 meters) deep. The material in the system shall be high enough and of a composition that will decelerate the landing. When the landing system is made up of two or more sections, the landing surface shall include a common cover or pad extending over all sections.

The front sections of the landing system, known as front buns, shall be a minimum of 16 feet, 5 inches (5 meters) wide so as to cover the entire area around the landing box to the inside edges of the standard bases up to the front edge of the plant box. The maximum cutout for the planting box shall be 36 inches (914 millimeters) in width, measured across the bottom of the cutout. The edges of the front of the landing system immediately behind the planting box shall not be placed more than 3 inches (76 millimeters) from the top of the back of the planting box. The front pad shall be attached to the main landing pad or encased in a common cover.

**NOTE:** In the pole vault, the front cutout tapered away from the planting box allows the pole to bend uninhibited.

Hard or unyielding surfaces, such as but not limited to concrete, metal, wood or asphalt around the landing pad, or between the planting box and the landing system, shall be padded or cushioned with a minimum of 2 inches (50 millimeters) of dense foam or other suitable material(s).

**NOTE:** It is recommended that any excess material such as asphalt or concrete that extends out from beneath the landing pad be removed.

The width between the pins that support the crossbar shall be not less than 13 feet, 8 inches (4.16 meters) or more than 14 feet, 8 inches (4.48 meters) apart. The pins shall be round, of uniform thickness not exceeding  $\frac{1}{2}$  inch (13 millimeters) in diameter, with the upper surfaces smooth, without indentations or aids of any type which might help hold the crossbar in place.

The pins shall project at right angles from the side which is opposite the runway and shall not exceed 3 inches (76 millimeters) in length from the upright. Cantilevered uprights may be used. The specifications for the crossbar are the same as those for the high jump. The standards shall have all exposed projections on the base covered or padded and be secured in a way as to prevent them from tipping over.

The nonmetal crossbar shall not be less than 14 feet, 8 inches (4.47 meters) and not more than 14 feet, 10 inches (10.52 meters) in length, of uniform thickness, and shall have a weight of not more than 5 pounds. It shall be circular with a diameter of not more than  $1\frac{3}{16}$  inches and with the ends flattened to a surface of  $1\frac{3}{16}$  inches by 6-7 $\frac{1}{4}$  inches (150-200 millimeters). In addition to the commonly used four-sided flat crossbar ends, the use of a crossbar fitted with alternative ends (semi-circular) is permitted.

A planting box shall be located midway between the standards. This box shall be constructed of concrete, fiberglass, metal, or other hard surface material into which the vaulting pole is placed so that the top edges are at ground level. The front edge of the box shall not extend above the grade of the runway surface. The box shall be of dimensions indicated in Diagrams A and B (page 51), and it shall be placed so the top edges are at ground level. The box in Diagram B shall be constructed so that the sides slope outward at the end nearest the landing pit.

The stopboard at the end of the planting box shall be placed at an angle of 105 degrees with the base of the box.

The runway adjacent to the pole vault box may be marked by a permanent line,  $\frac{1}{2}$  inch or 1 centimeter drawn through the top (zero point) of the vault box extending 10 feet (3 meters) to each side of the box.

**NOTE:** It is recommended the planting box be of a color contrasting to the color of the runway.

A minimum of 2-inch (51 millimeters) dense foam padding (box collar) shall be used to pad any hard and unyielding surface including between the planting box and all pads.

The plant box padding shall meet the ASTM Specification Standards and can be incorporated into the design of the planting box or can be a padding addition to an existing planting box.

**DISCUS** — The throwing circle shall be 8 feet, 2½ inches (2.50 meters) in diameter. The circumference shall be marked with a metal, wood or plastic band which shall not rise more than ¼ inch (1.9 centimeters) above the level of the circle or if the circle has a surface of asphalt, concrete, wood or other hard material, a painted line 2 inches (5 centimeters) wide may substitute for the band. The inside edge of the line or band is the limit of the throwing circle.

Projecting lines, 2 inches (5 centimeters) wide and 8 inches (20 centimeters) long, lying on the diameter extended and outside the circumference shall be used to designate the back half of the throwing circle.

A 34.92-degree sector shall be marked on the ground and drawn from the center of the throwing circle. From the center of the circle, mark one sector line. To establish the other sector line, use the point of intersection of the first sector line and the inside edge of the throwing circle and strike an arc with a radius of 2 feet, 5⅞ inches (75.07 centimeters), so that it intersects the circle. From the center of the discus circle and through this point, construct the second sector line.

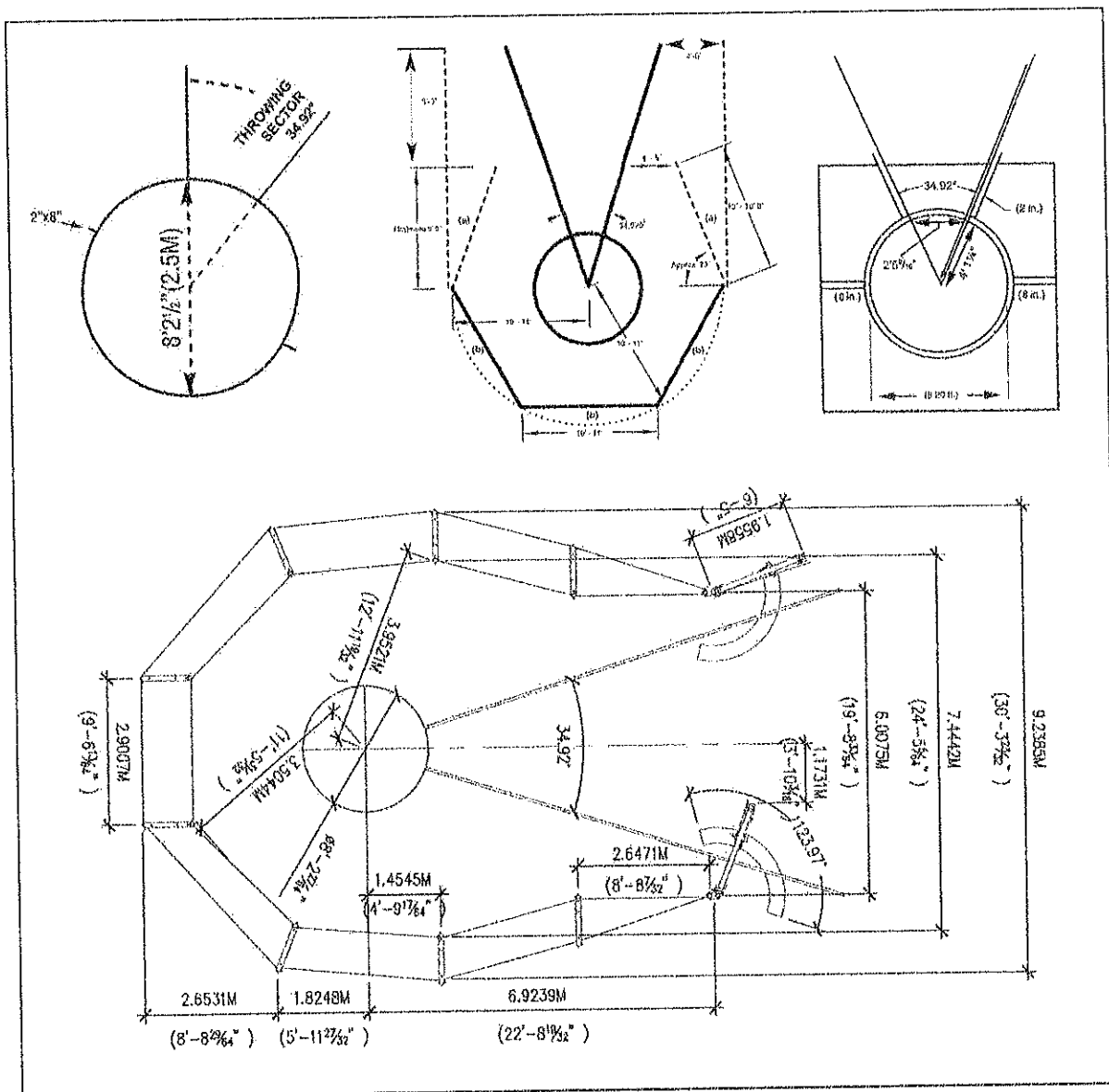

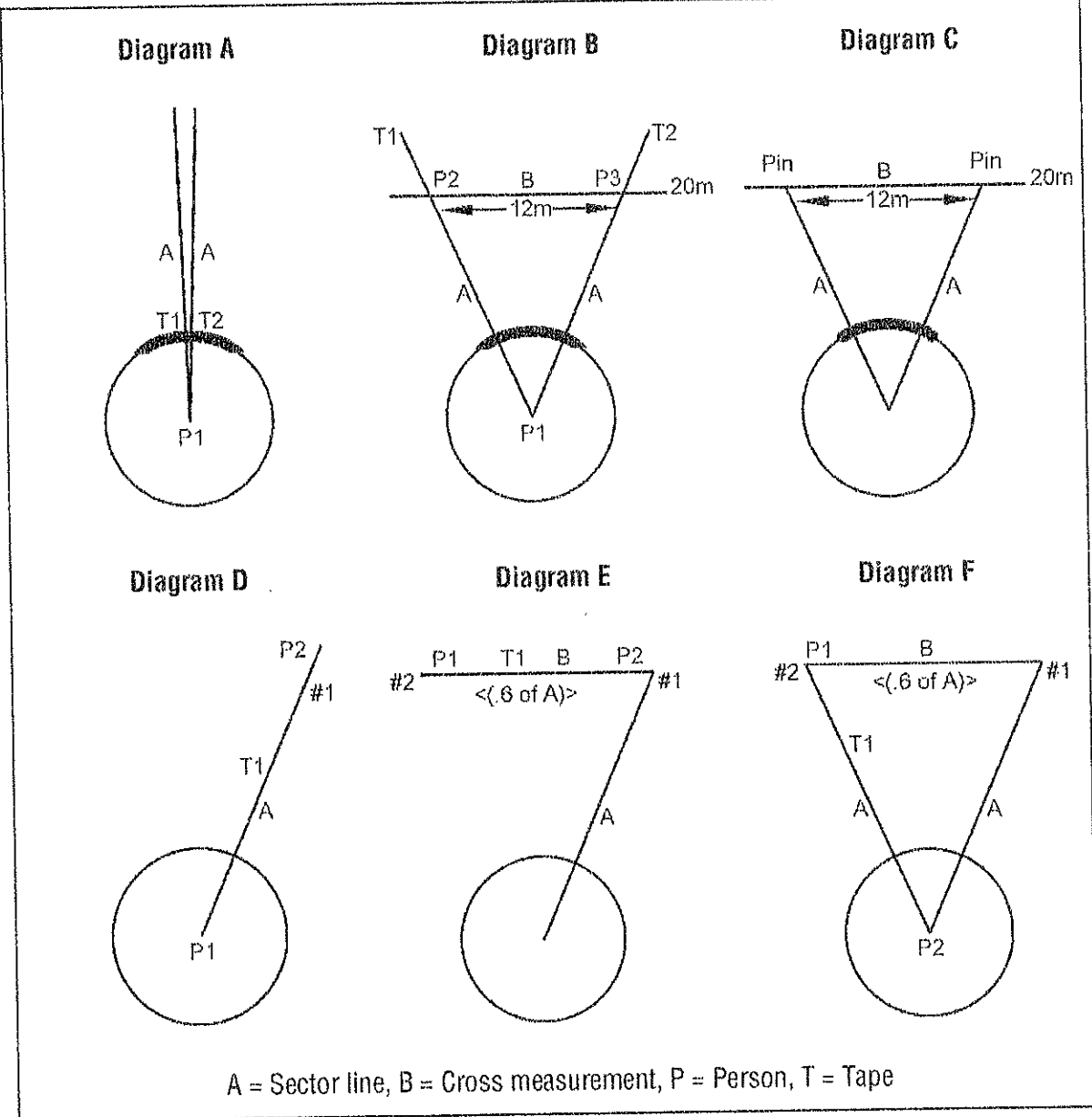
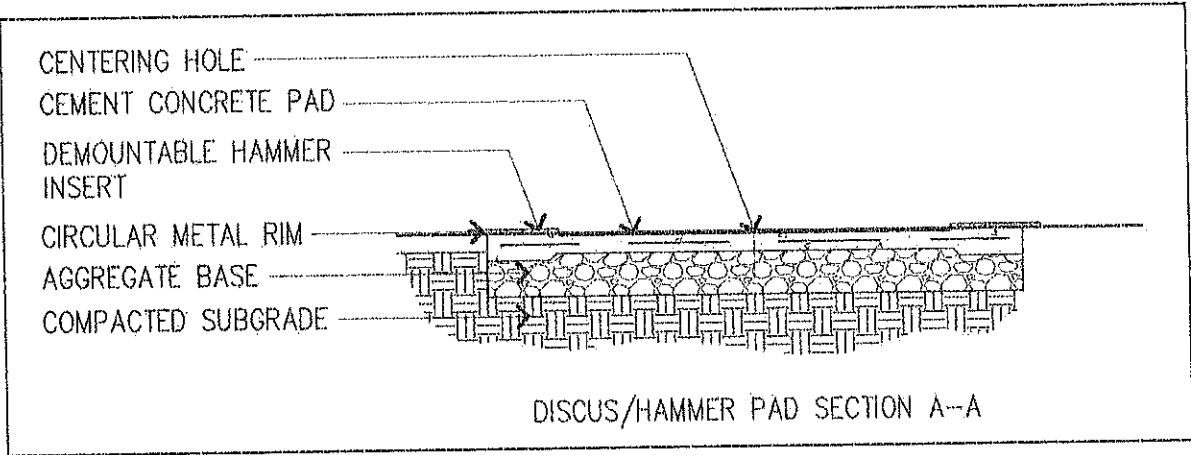

## SUGGESTED DISCUS CAGE SPECIFICATIONS

Portable or permanent installation. It is recommended that the cage be constructed of heavy nylon netting or other material that will absorb the energy of the discus to prevent bounce back. There must be a rear to the cage as well as sides that extend forward at least to the front of the ring and preferably several feet beyond the front of the ring.

Height: 10 feet to 14 feet

Front Opening: 20 feet to 24 feet measured across the center circle

Distance from Corner Post to Sector Line: 4 feet to 5 feet

Distance from Center of Circle to Fencing: 10 feet to 11 feet

Fencing: Energy-Absorbing Material

(a) 10 feet to 10 feet, 6 inches

(b) 10 feet to 11 feet

### NOTES:

1. The ends of the cage (wing/gate pole) should be placed within 4 to 5 feet of the sector lines.
2. The above diagram of a discus throwing cage is designed to provide limited protection for competitors, officials and spectators in the immediate throwing area. Due to the nature of the event, it does not ensure the safety of the aforementioned personnel.
3. It is recommended that all throwing areas be corded off with rope, fence or flags placed well outside the sector lines to minimize the risk of injury for spectators and athletes.

**SHOT PUT** — A 34.92-degree sector shall be marked on the ground. The putting circles shall have an inside diameter of 7 feet (2.134 meters). The circumference shall be marked with a metal, wood or plastic band which shall not rise more than  $\frac{3}{4}$  inch (1.9 centimeters) above the level of the circle; or, if the circle has a surface of asphalt, concrete, wood or other hard material, a painted line 2 inches (5 centimeters) wide may be substituted for the band. A concrete surface with a  $\frac{1}{16}$  inch (1 millimeter) roughness is recommended.

A stopboard, constructed of concrete, fiberglass, metal, wood or other hard-surfaced material in the shape of an arc, so that the inner edge coincides with the inner edge of the circle, shall be firmly fixed in this position. It shall be 4 feet (1.22 meters) in length along the inside surface, 4 inches (10 centimeters) in height and 4½ inches (11.4 centimeters) in width. The inside edge of the line or band is the limit of the putting circle.

Radial lines 2 inches (5 centimeters) wide shall extend from the center of the circle to form an area into which legal puts must be made. The inside edges of these lines shall mark the sector and the lines shall be placed equidistant from the ends of the stopboard.

Projecting lines, 2 inches (5 centimeters) wide and 8 inches (20 centimeters) long, lying on the diameter extended and outside the circumference, shall be used to designate the back half of the throwing circle.

**JAVELIN THROW** — The runway for the throw should have a minimum length of 120 feet (36.5 meters) and shall be marked by two parallel lines, 13 feet, 1½ inches (4 meters) apart and terminated by a foul-line arc with a radius of 26 feet, 3 inches (8 meters) as shown below. The foul-line arc shall be marked with a white metal, plastic or wood band 2¾ inches (7 centimeters) in width. If using a band, the top surface shall be level with the throwing surface. The line or band shall be in the throwing sector with the edge toward the runway coinciding with the foul-line arc. A line 2¾ inches (7 centimeters) in width and 2 feet, 5½ inches (75 centimeters) in length shall be placed or painted on each side of the runway perpendicular to the side boundaries at the intersection of the foul-line arc and inside of the side boundary lines.

The throwing sector is that area defined by extending radii through the two intersections of the arc with the runway lines and a point midway between the runway lines and 26 feet, 3 inches (8 meters) from the foul line.

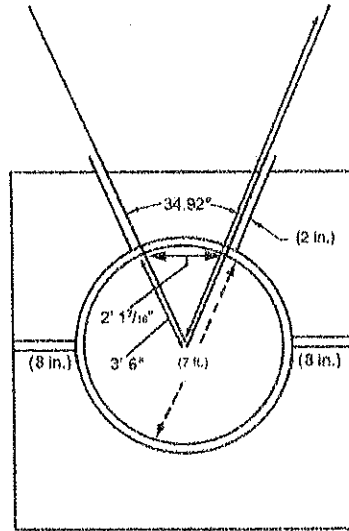
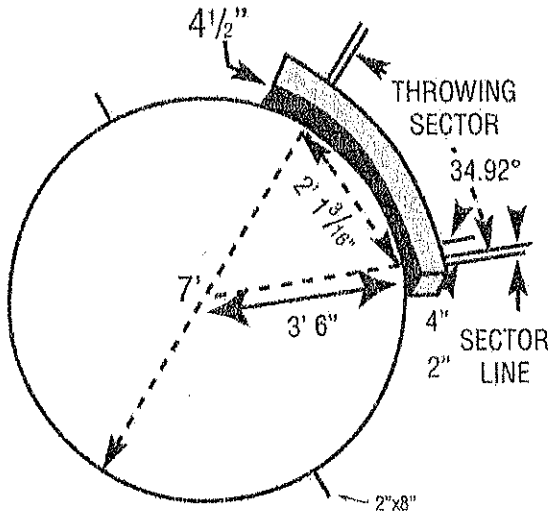

SHOT PUT PAD PLAN VIEW

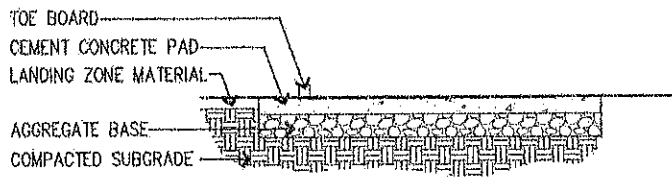

NOTE:

SHOTPUT TOE BOARDS VARY. COORDINATE WITH MANUFACTURER/DESIGNER FOR PROPER PLACEMENT AND INSTALLATION

SHOT PUT PAD SECTION A-A

